

INDUSTRIAL CRANES
NUCLEAR CRANES
PORT CRANES
HEAVY-DUTY LIFT TRUCKS
SERVICE
MACHINE TOOL SERVICE

REACH STACKERS

KONECRANES®
Lifting Businesses™

10 – 80 tons REACH STACKERS WITH HEART







Remarkable versatility

FROM CONTAINERS TO INDUSTRIAL CARGO

We have a long history of working with container ports and intermodal terminals that are expert buyers and operators of reach stackers. Our container handling customers demand a lot of us, and we have a long track record of meeting their requirements year after year.

Larger reach stackers are needed for railroad stacking. To load and unload on more than one track you need a flexible reach stacker with a large lifting capacity and an extended set of functions. You will find a reach stacker in our range that will meet the specific requirements of your terminal.

Industrial workhorses

We also work with many industrial companies that need customized reach stackers for their specific industry. Our reach stackers are remarkably adaptable to industrial cargo handling. We provide special spreaders incorporating steel grabs, lifting magnets, vacuum grippers and coil C-hooks among other attachments. What kind of material do you need to lift and move? Contact us. You'll probably find we have plenty of experience in your industry and can provide the ideal reach stacker.

Applications

- Container ports and terminals
- Railroads and intermodal
- Trimodal river handling
- Transport, shipping and logistics
- Steel and aluminum
- Automotive
- Oil and gas
- Wind power
- Nuclear power
- Waste-to-energy



This publication is for general informational purposes only and we reserve the right at any time to alter the product design and specifications. No statement of this publication shall be construed as a warranty or condition, express or implied, as to any product, its fitness for any particular purpose, merchantability, quality or representation of the terms of any sales agreement.

Courtesy of Machine.Market

**Made with heart
in every detail**

SMARTER WHERE IT MATTERS

Konecranes has been manufacturing, selling and supporting heavy-duty lift trucks for some 60 years. Buy a reach stacker from us today and you will get the latest technology, the lowest Total Cost of Ownership, and a reach stacker made with heart.

We claim the lowest Total Cost of Ownership with our reach stackers, understood as an equation running over a time period of years as shown below. When you're shopping around the suppliers and comparing prices, our truck will probably not be the cheapest. But it will provide the best value over time.

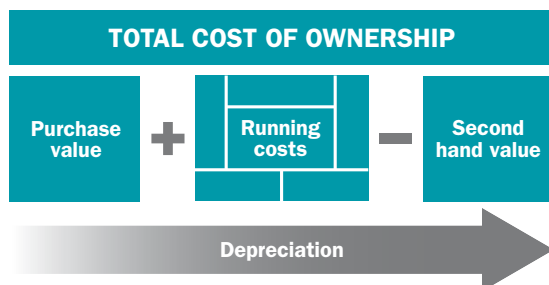

Close to you

We sell our lift trucks around the world in two ways: directly via our own sales and service organizations in about ten countries, and indirectly via distributors in more than 80 countries. In both cases, our trucks are fully supported with quickly delivered spare parts and personalized service. Konecranes has the widest service reach of any company in the lifting business. And our distributors are some of the most respected in the business.

Service made easy

To reduce lifetime running and maintenance costs we have extended the service interval of the engine by 500 hours, the gearbox by 1000 hours and the hydraulics by 4000 hours.

Our HLL ultra-fine filter system extends the hydraulic oil change interval from 4000 up to 12000 hours. In practice, you will use up to 80% less hydraulic oil than with a conventional hydraulic system.

GENUINE KONECRANES PARTS

Genuine Konecranes parts are the best protection for your investment. They pay off in truck performance and uptime.

PARTS ONLINE

> Easy to find, easy to buy

REAL-TIME SHIPMENT INFORMATION

> You know where your parts are

FAST DELIVERY

> Parts in stock are in your hands within 1–3 days

PROTECTION BOX

> All the filters you need, in one package

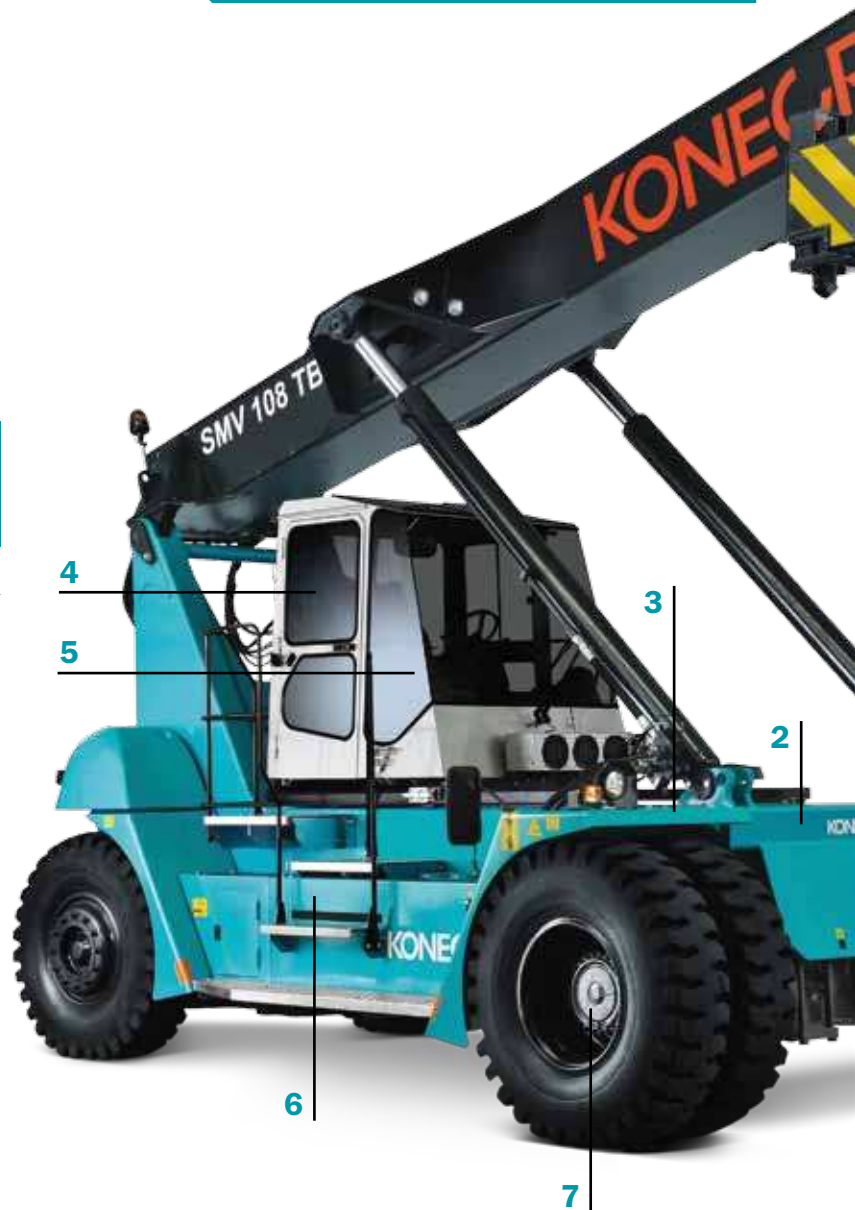



1 Modern and durable lifting spreaders

Top-lift for 20/40/53 ft containers, 300 degrees rotation, 1600 mm total side-shift, 4 lift eyes for sling cargo. MPS mechanical (± 2 deg) or HPS hydraulic pile slope (± 6 deg). The combi spreader can also lift trailers and swap bodies with 4 folding lift legs.

2 Smart load-sensing hydraulics

They sense the load and adapt the lifting power to the weight of the load. The truck provides maximum power only when really needed, so it consumes less fuel while reducing emissions and noise.

3 Powerful engine

Certified low-emission engine provides extra high torque at low revs for reduced fuel consumption and low noise levels. We offer a variety of engines for EU stage 2/3a/3b and EPA Tier 2/3/4i.

1

4 ErgoCab, probably the best cabin on the market

Every detail has been carefully designed for comfort and safety. Controls, displays, ventilation and seating work to boost driver productivity. Excellent visibility in all directions.

5 Intelligent Electronic Machine Control, EMC Master

Full monitoring of all the vital components and functions. Programmable settings. CanBus technology increases engine and transmission reliability.

6 Heavy-duty box-type chassis

The strongest on the market. The foundation of long-lasting high performance.

7 Maintenance-free brakes

Brakes with continuous oil cooling provide full braking power in every situation.

8 Excellent stability

Wide, strong drive axle and long wheelbase. The two keys to excellent stability for safe lifting of heavy loads.

8

Intermodal operations, Helsingborg, Sweden



Satisfied customers
around the world
**OUT IN
THE FIELD**

Worldwide, Konecranes reach stackers are hard at work across an amazing range of container handling and industrial applications.

Multi-purpose operations, Germany



Laden container handling, Norway



Steel slab handling, Finland



Empty container handling, Germany



La Spezia, Italy



Intermodal operations, UK



Laden container handling, China



Oil and gas pipeline handling, Norway



Intermodal operations, Helsingborg, Sweden



ErgoCab

TRULY SPACIOUS, REMARKABLE VISIBILITY

Customized precisely as you need.

Step inside and you will find that ErgoCab is truly spacious: there is plenty of room for the driver and any extra equipment you might require.

You will also be struck by the remarkable visibility. The windows are very large. There are no corner posts, and the roof cross member is very strong but thin. We have done everything possible to ensure clear sightlines to the key working areas, both in the front, to the sides and to the rear.

You can customize ErgoCab precisely as you require for your container handling operation. Select the joystick, joystick panel, steering wheel, driver's seat and instrumentation that you need. Also available: a hydraulic sliding cabin (stroke 2900 mm), a vertically movable cabin RHS (stroke 2850 mm), and EMC remote control.



Remote control unit for rail and barge handling

1 Remarkable visibility

Visibility is very difficult to measure objectively: you just know it when you see it. Sit down in ErgoCab, see what visibility from a lift truck cabin can be.

2 Intelligent Electronic Machine Control

Our EMC Master system gives the driver real-time information on truck performance including full monitoring of the engine, transmission, hydraulics and joystick.

3 Left armrest mini-steering options

Optional, ergonomic steering solutions that improve productivity.

4 Ergonomic instrumentation

Whatever extra equipment you need, we can install it as part of an ergonomic instrumentation layout. ErgoCab is truly spacious.

5 Comfort

An excellent seat with compressor suspension, powerful cabin heating and ventilation, air conditioning – the driver is provided with every possible comfort.

6 Joystick control

Available with electronic joystick and auto throttle.

3 Left armrest mini-steering options

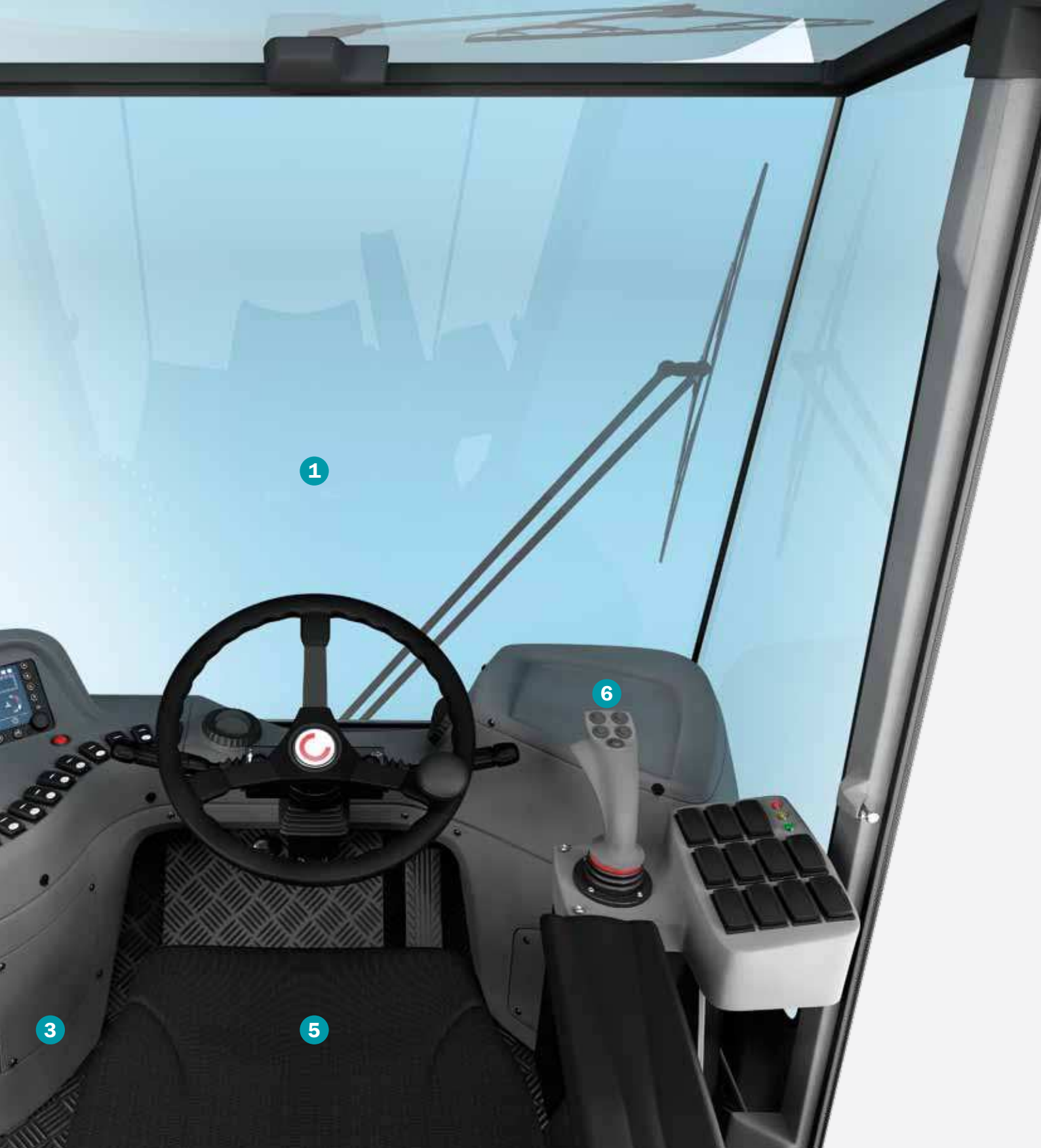

1

2

3

4



Lever steering with return



Mini-wheel steering



Lever steering without return

A world of options

BOOSTING SAFETY AND EFFICIENCY

Konecranes invests significantly in reach stacker R&D to be the first to offer new technologies that improve performance and safety. We also ensure that our reach stackers are fully compliant with emissions regulations, anticipating their evolution as a normal part of our product development process.

Emissions-compliant diesel engines

We offer a wide range of powerful Volvo, Scania and Cummins engines certified according to EU stage 2/3a/3b and US EPA Tier 2/3/4i. For EU stage 2 or 3a / US EPA Tier 2 or 3 compliance we can offer additional 2-way catalyzers or particle filters (including a catalyzer) to reduce exhaust emissions.

EMC Master

Our Intelligent Electronic Machine Control system, EMC Master, provides the following functions as standard:

- Electronic overload & safety system
- Load management
- Full truck monitoring
- ECO-Drive and fuel management
- Productivity counter management
- Driver log-in (20 drivers)
- Data logging of alarms and errors
- Transport mode (boom/spreader load optimizer)

The following functions are optional:

- Vertical auto-lift function
- Horizontal auto-lift function
- Remote control unit (railroad/barge loading)
- Mini-wheel steering
- Mini-lever steering
- Auto engine shut-down
- Auto parking brake
- Drive speed limitation (unloaded/loaded)
- Remote Access Service (via GSM)

NearGuard warning system

The award-winning NearGuard warning system is based on Radio Frequency Identification (RFID) technology. The system consists of 2–4 receivers mounted on the reach stacker and RFID tags attached to obstacles and/or employees working in the lift truck's operating area. When the reach stacker is driven in close proximity to a tagged obstacle or employee, the driver sees a flashing warning indicator on the EMC control system's color display. NearGuard brings a powerful new dimension to reach stacker safety and infrastructure protection.

Tire pressure monitor

Under-inflated tires can increase fuel consumption by as much as 15% while impairing stability and drivability. Our tire pressure monitor makes it easy to keep your lift truck tires properly inflated. It's installed in minutes. If you combine it with the drive speed limitation provided by EMC Master you can extend the life of your tires even further.

Fire alarm and suppression system

We offer an effective fire alarm and suppression system that can be activated either manually or automatically. When the reach stacker is in use, the system discharges in one of three ways: manually from inside the cabin; manually from outside via a mudguard trigger; automatically, triggered by sensors in the engine compartment. When the reach stacker is not in use, i.e. when the master power switch is turned off, the system discharges automatically when the fire alarm goes off.

Other safety options

- Parking Distance Control (PDC) with sensors for driving in reverse.
- Breath Analyzer: an alcohol test unit which requires the driver to take a breath test before starting the reach stacker.
- Camera Supervision System: can be mounted as a reversing camera on the rear of the reach stacker or as a forward camera mounted on the spreader or chassis.

1



2



3



4

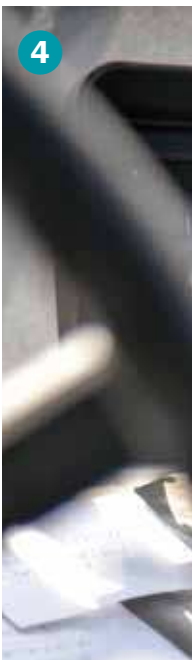



- 1 EMC Master monitor
- 2 TURBO 2 air filter for engine, 2-stage cyclone heavy duty filter with indicator
- 3 Tire pressure monitor
- 4 Reverse camera display
- 5 Elevating cabin for railroad operations, stroke 2.9 m, to see over the 1st rail set and load on 2nd rail set. Up to 10 extra lamps for improved visibility: choose between Halogen, Xenon and LED
- 6 Joystick instead of levers
- 7 Cabin options: touch screen, keyboard, reading lamp, side mirror, side-mounted roof wiper, sun visor roof & front, compressor seat etc.

What do you need to lift?

WE HAVE THE ATTACHMENT

You'll find your lifting solution in our complete range of attachments for reach stackers.



Container handling



ELME 517-MPS

Telescopic spreader for empty ISO containers with capacity up to 10 tons. Strong and well-proven single beam spreader design, floating twistlock (± 10 mm) with hydraulic operation and mechanical safety locking. Hydraulic extension with 2 cylinders (20–40 ft), large sideshift (± 800 mm) with 2 hydraulic cylinders and full rotation ($-105/+195$ deg) with 1 hydraulic motor (turning) and 1 brake (holding). Spreader side tilt ± 2 deg (MPS = mechanical pile slope). The spreader frame and the end beams are of strong heavy-duty design. Weight = appr. 4.8 tons.



ELME 817-MPS

Telescopic spreader for laden ISO containers with capacity up to 45 tons. Strong and well-proven parallel double beam spreader design, floating twistlock (± 10 mm) with hydraulic operation and mechanical safety locking. Hydraulic extension with 2 cylinders (20–40 ft), big sideshift (± 800 mm) with 2 hydraulic cylinders and full rotation ($-105/+195$ deg) with 1 hydraulic motor (turning) and 2 brakes (holding). Spreader side tilt with stroke of ± 2 deg (MPS = mechanical pile slope) and 4 lift eyes included for slings (45 tons). ELME 817-HPS with a stroke of ± 6 deg (HPS = hydraulic pile slope with 4 cylinders). The spreader frame and the end beams are of strong heavy-duty design. Weight 817-MPS/HPS = appr. 9.3/10.3 tons.



ELME 817-MPS/OFL (folding)

With overheight folding legs for open-top containers and flat racks (extra high cargo). The foldable extension legs are 1600 or 2100 mm long and activated by 4 cylinders. Weight appr. 10.3–11.3 tons.



ELME 817-MPS/OFL in action

Above, legs shown in unfolded position with an open-top container with high cargo. Flat racks often have overheight cargo that must be lifted like this.

Also available

- Pipe and tube handling attachment
- Clamp for steel handling

Several others available upon request



Intermodal handling



Industrial handling



ELME 857-HPS (folding)

Telescopic intermodal spreader (combi/piggyback) for laden ISO containers, swap bodies and trailer handling with capacity up to 45 tons (in twistlocks/in lift legs). Extension 20/30/40 ft is included. The lift legs “fold in” and “fold out” in a sequence with sensors in each lift leg / lift shoe. Leg length = 3100 mm and leg opening = 1700–3200 mm. The package of spreader frame and legs is of strong heavy-duty design. All container functions as for ELME 817-MPS/OFL. Weight appr. 13.6 tons.



ELME industrial tool carrier system

For connecting tools (connection points = 2500 x 760 mm). Strong and well-proven single beam spreader design, floating twistlock (± 10 mm) with hydraulic operation and mechanical safety locking. Large sideshift (TC-50 = ± 500 mm / TC-65 = ± 300 mm) with 1 hydraulic cylinder and full rotation ($-105/+195$ deg) with 1 hydraulic motor (turning) and 1 brake (holding). Spreader side tilt ± 2 deg (MPS) or ± 6 deg (HPS). The spreader frame and the end beams are of strong heavy-duty design. Weight TC-50-MPS/TC-65-MPS = appr. 5.0–7.5 tons.



ELME 857-HPS in action

Legs shown in unfolded position with a trailer being lifted.



Hydraulic steel slab grab unit

Hydraulic steel slab grab unit with pairs of hydraulic lifting jaws. The grab can lift 1–4 slabs if the height adjustment function is included. Various slab width combinations are available, width min-max 700–1800/900–2000/1500–2600 mm. Capacities up to 50 tons (in grab unit). Grab weight = appr. 9.0–12.0 tons.

EQUIPMENT

For all Konecranes reach stackers

STANDARD EQUIPMENT

TRUCK BODY

Box-type chassis

- Strong box profile and cross-members
- Thick steel plate reinforcement, both front and rear
- Safe, ergonomic access steps and hand rails LHS+RHS
- Strong lift cylinder and boom fixations in chassis
- Lifting eyes, front and rear in the chassis/boom

Standard colors

- Chassis, tanks, mudguards & rear: seagreen NCS S2555 B30G
- Mast, carriage, spreader & axles: black RAL 7021
- Cabin & engine hood: light grey RAL 70335

Steel mudguards

STEERING AXLE

- Smooth power steering with double-acting cylinder
- Wide steering angles providing small turning radius

DRIVE AXLE

Kessler D81/102/106/111

- Wide axle with 2-stage hub reduction and differential
- Oil-cooled, maintenance-free wet disc brakes

DIESEL ENGINE

See technical info charts

- Certified for EU stage 2, 3A, 3B / EPA Tier 2, 3, 4i
- Low-emission
- Clean, powerful, fuel-efficient with CanBus controls

Engine air filter, 2-stage type

TRANSMISSION

108-2518; DANA TE-17 (3+3 gears)

4123-4545; DANA TE-27 (4+4 gears)

- Fully automatic, softshift
- Torque converter, smooth powershift, declutch, reverse protection, CanBus controls

COOLING SYSTEM

Tropical, multi-radiator

- Radiators for engine water, air for intercooler, oil for transmission
- Oil cooling / flushing for brakes

HYDRAULIC SYSTEM

Load-sensing, power-on-demand

- Smooth, accurate, high-speed lifting and lowering
- Variable piston pumps with intelligent control
- Leak-free ORFS couplings (O-ring) for entire truck
- Large dual tanks for hydraulics and brakes with return filters (12 microns)

ELECTRICAL SYSTEM 24 V

Alternator standard size 55–110 Ah

LIGHTS

- Full road lighting (in Halogen): blinkers, brake lights, tail lights, position lights
- 2 x Halogen high beam / low beam headlights front
- 2 x Halogen reverse lights rear
- 4 x Halogen work lights on lift boom
- 2 x Halogen work lights on spreader

OPTIONAL EQUIPMENT

TRUCK BODY

- Fire extinguisher on truck body or inside cabin
- Fire fighting system for driveline compartment (semi-automatic)
- Galvanized storage boxes with lid (on bottom step)
- Central greasing unit for truck and spreaders
- Custom colour painting, stickers & customer logos

Different mud flap models, front and rear

STEERING AXLE

- Wheel nut protection and steering cylinder spacers

DRIVE AXLE

DIESEL ENGINE

- SMV 108-2518: Volvo and Cummins (180–201 kW / 990–1180 Nm)
- SMV 4123-4545: Volvo, Scania and Cummins (256–294 kW / 1640–2172 Nm)
- Certified for EU stage 2, 3A, 3B / EPA Tier 2, 3, 4i
- Low-emission
- Clean, powerful, fuel-efficient with CanBus controls
- Engine air filter Turbo II, 2-stage cyclone type

TRANSMISSION

SMV 108-2518; ZF 4WG-191 (4+3 gears)

SMV 4123-4545; DANA TE-32 (4+4 gears) and ZF 4WG-261 (4+3 gears)

- Fully automatic, softshift
- Torque converter, smooth powershift, declutch, reverse protection, CanBus controls

COOLING SYSTEM

- Extra radiator / cooling circuit for hydraulic system

HYDRAULIC SYSTEM

- High pressure filters (12 um)
- HLL hydraulic longlife filters (3 um)
- Hydraulic oil cooling circuit for working hydraulics

ELECTRICAL SYSTEM 24 V

- Larger alternator, 80–150 Ah
- Reverse alarm (beeping)
- NearGuard RFID warning system (receiver and transmitters)
- NATO starting aid contact
- Built-in battery charger
- Pre-heater for engine, transmission, hydraulics and cabin
- Power connections 400V/3-phase for multiple preheaters

LIGHTS

- Full road lighting (in LED): blinkers, brake lights, tail lights, position lights,
- Extra work lights: Halogen (70 W), Xenon (3250 Lum), LED8 (1660 Lum) or LED16 (2900 Lum)
- LED warning beacons
- LED strobe warning flash lights: front, rear or other position

STANDARD EQUIPMENT

CABIN

ErgoCab size large (L), two doors
L x W x H = 1580 x 1450 x 1620 mm
Sliding cabin
TB models: manual sliding, stroke 1800 mm
CB models: hydraulic sliding, stroke 2900 mm
Spacious, comfortable, excellent ergonomics
Excellent visibility: no front corner posts
Powerful heating and cooling unit
Electrical connection 24V (1 x in cab roof RHS)
3 x windshield wipers / washers
Adjustable seat, seat belt, steering wheel
Joystick (electronic servo / auto throttle)

MACHINE CONTROL

EMC Master intelligent machine control, display: MDL2, size 6.5"
Monitoring of engine, transmission, hydraulic system, service, electronic joystick, spreader, counters and info
EMC Safety, overload and load management system
EMC 106: Monitoring (diagnostics/parameters/settings)
EMC 114: Electronic servo joystick (auto-throttle)
EMC 123: ECO-Drive (fuel consumption, saving, settings)
EMC 124: Driver log-in (up to 20 drivers)
EMC 125: DATA-Log (storage of alarms and errors)
EMC 129: Productivity Hour Counter
EMC 130: Transport mode (boom/spreader position)

BOOM

2-stage box-type lift boom
Strong box profile and cross-members
Thick steel plate reinforcement, both front and rear

SPREADERS

SMV 108: ELME 517 (10 t)
Stops 20–40 ft, 4 floating twistlocks, rotation 300 deg
Mechanical Pile Slope ± 2 deg, sideshift ± 800 mm
SMV 4127-4545 TB: ELME 817 (45 t)
Stops 20–40 ft, 4 floating twistlocks, rotation 300 deg, 4 lifting eyes
Mechanical Pile Slope ± 2 deg, sideshift ± 800 mm
SMV 4123-4545 CB: ELME 857 (45 t)
Stops 20/30/40 ft, 4 floating twistlocks, 4 lifting eyes,
Hydraulic Pile Slope ± 6 deg, sideshift ± 800 mm
PDC Power Damp Control + tilt lock, 4 lifting legs

INDUSTRIAL HANDLING

Models SMV 108-2518-4127-4545 TB

SERVICE AND PARTS

Standard warranty 12 months / 2000 hours
--

OPTIONAL EQUIPMENT

CABIN

TB models: hydraulic sliding, stroke 2900 mm
TB/CB models: vertical moveable cabin RHS, stroke 2850 mm
Extra mirrors inside cabin
Reverse, front and spreader cameras with 6.7" display (MOTEC)
Air conditioning or climate control unit (stepless fan speed)
Extra electric cabin heater 220V (DEFA)
Extra diesel-powered cabin heater (Webasto)
Extra electrical connections 24V (cab roof or front panel RHS)
Extra electrical connections 12V (cab roof or front panel RHS)
Interval wiper speed switches: front, roof and rear windows
Pneumatic compressor horn
Various seats BEGE, ISRI, Grammer
Additional seat dampening: single or double
Two-point or three-point seat belt
Seat heating
Extra trainer's seat, leather, fully-foldable LHS
Tire pressure monitor: cabin display, 6 tire sensors
Sun blinds: front, roof or rear windows, fixed or adjustable
Alcohol lock / start-up prohibitor (Draeger)
Reverse alarm (beeping)
Universal mounting system for RHS for A4/A5 writing pad, keyboard, computer, monitor, com radio and reading lamp
CD player / radio / MP3 player with dual loudspeakers

MACHINE CONTROL

EMC 102: Lever steering (with spring return to zero)
EMC 103: Lever steering (no spring return to zero)
EMC 104: Mini-wheel steering (speed progressive steering function)
EMC 105: Mini-wheel steering (not progressive steering function)
EMC 107: Electronic weight scale (resolution 0.1 ton)
EMC 112: Auto engine shut-down timer
EMC 122: Drive speed settings (on/off, programmable)
EMC 126: GSM remote access
EMC 131: Vertical lift
EMC 132: Vertical lift / horizontal outreach
EMC 133: Remote control units for rail and barge handling
NearGuard RFID warning system (receiver and transmitters)

BOOM

Long-nose boom to reach ground level (extended 1000 mm)
Long-nose boom to reach ground level (extended 1500 mm)
Distance piece (extended 1500 mm) between nose and rotator (for barge)
Distance piece (extended 2000 mm) between nose and rotator (for barge)

SPREADERS

Extra stops at 24/30/35 ft
Hydraulic Pile Slope ± 6 deg
Extra stops at 24/30/35 ft
Hydraulic Pile Slope ± 6 deg
Power Damp Control (PDC) + tilt lock
Over-height folding legs 1600 and 2100 mm
Separate ELME 952/953 Bottom Trailer Lift (2/4 fold legs)
Extra lifting eyes 2 x in centre or 4 x at 2500 mm distance
Extra stops at 24/35 ft

INDUSTRIAL HANDLING

ELME 7000 and 7010 tool carriers (50 and 65 tons)
Steel slab grab, coil hook for coils, magnet for steel (mounted on tool carrier)
Lifting hook on boom nose, free pivot, free rotation, no power (30–80 tons)

SERVICE AND PARTS

Extended warranty on truck and driveline (18–36 months / 3000–6000 hours)
Spare tires, rims, complete wheels: various brands
Spare part kits: basic, extended, special
Complete filter kits: 2000 hours up to 8000 hours

PREMIUM PERFORMANCE IS WITHIN YOUR REACH

Reach stackers for container handling, 10 to 45 tons



MODEL NAME	CAPACITY	WHEELBASE
SMV 108 TB6	10-8-5 tons	5000 mm



MODEL NAME	CAPACITY	WHEELBASE
SMV 2115 TB3	21-15-5 tons	5500 mm
SMV 2518 TB3	25-18-8 tons	5500 mm



MODEL NAME	CAPACITY	WHEELBASE
SMV 4127 TB5 (TB6)*	41-27-14 tons	6400 mm
SMV 4527 TB5 (TB6)*	45-27-14 tons	6400 mm
SMV 4531 TB5 (TB6)*	45-31-16 tons	6400 mm



MODEL NAME	CAPACITY	WHEELBASE
SMV 4535 TB5 (TB6)*	45-35-20 tons	6400 mm
SMV 4535 TBX5**	45-37-24 tons	6400 mm
SMV 4537 TB5	45-37-19 tons	6400 mm
SMV 4537 TBX5**	45-41-28 tons	6400 mm



MODEL NAME	CAPACITY	WHEELBASE
SMV 4542 TB5	45-42-24 tons	7250 mm
SMV 4542 TBX5**	45-44-30 tons	7250 mm
SMV 4543 TB5	45-42-25 tons	7500 mm
SMV 4543 TBX5**	45-44-34 tons	7500 mm



MODEL NAME	CAPACITY	WHEELBASE
SMV 4545 TB5	45-45-37 tons	8000 mm
SMV 4545 TBX5**	45-45-45 tons	8000 mm

Reach stackers for intermodal handling, 41 to 45 tons



MODEL NAME	CAPACITY	WHEELBASE
SMV 4123 CB5	41-23-9 tons	6400 mm
SMV 4527 CB5	45-27-13 tons	6400 mm
SMV 4531 CB5	45-31-16 tons	6400 mm
SMV 4531 CBX5***	45-33-20 tons	6400 mm
SMV 4533 CB5	45-33-16 tons	6400 mm
SMV 4533 CBX5***	45-37-24 tons	6400 mm

Reach stackers for barge handling, 45 tons



MODEL NAME	CAPACITY	WHEELBASE
SMV 4542 TB4 BH	45-37-23 tons (yard)	7500 mm
	43-30-18 tons (barge)	7500 mm
SMV 4542 TBX4 BH**	45-41-31 tons (yard)	7500 mm
	45-37-26 tons (barge)	7500 mm
SMV 4545 TB3 BH	45-45-35 tons (yard)	9000 mm
	45-37-30 tons (barge)	9000 mm



MODEL NAME	CAPACITY	WHEELBASE
SMV 4537 CB5	45-37-22 tons	7250 mm
SMV 4537 CBX5	45-40-28 tons	7250 mm
SMV 4538 CB5	45-38-23 tons	7500 mm
SMV 4538 CBX5***	45-40-32 tons	7500 mm

Reach stackers for industrial handling, 35 to 80 tons



MODEL NAME	CAPACITY	WHEELBASE
SMV 4127	35-50 tons	6400 mm
SMV 4527	35-50 tons	6400 mm
SMV 4531	35-50 tons	6400 mm
SMV 4535	35-50 tons	6400 mm
SMV 4542	40-60 tons	7250 mm
SMV 4545	40-80 tons	8000 mm



MODEL NAME	CAPACITY	WHEELBASE
SMV 4545 CB5	45-45-33 tons	8000 mm
SMV 4545 CBX5***	45-45-45 tons	8000 mm

*TB5 = 5 high, TB6 = 6 high
 **TBX = Capacity with support jacks engaged
 ***CBX = Capacity with support jacks engaged
Other models upon request

DRIVELINES

Reach stackers 10–25 tons

MODEL		SMV 108 – 2518			
Engine		Units			
Make		Volvo	Volvo	Cummins	Volvo
Model		TAD-722-VE	TAD-760-VE	QSB-6,7-C260	TAD-762-VE
Emission approval, EU / US		St 2 / Tier 2	St 3a / Tier 3	St 3a / Tier 3	St 3b / Tier 4i
Power / max speed (ISO 3046)	kW/rpm	180 / 2300	184 / 2300	201 / 2300	185 / 2300
Torque @ speed (ISO 3046)	Nm/rpm	1050 / 1400	1100 / 1500	990 / 1500	1180 / 1250
Displacement / cylinders	L/--	7.2 / 6-cyl	7.2 / 6-cyl	6.7 / 6-cyl	7.2 / 6-cyl
Alternator power / capacity	W/Amp	1540 / 55	2240 / 80	1960 / 70	2800 / 100
Fuel consumption (normal)	L/hour	8-12	7-12	7-12	7-12
Transmission (make / model)		DANA TE-17	DANA TE-17	DANA TE-17	ZF 4WG-191

MODEL		SMV 108 – 2518			
Transmission		Units			
Make		DANA	ZF		
Model		TE-17300	4WG-191		
Gear shift type		Automatic	Automatic		
No. of gears (fwd / rev)	No.	3 / 3	4 / 3		
Power rating (max)	kW	200	200		

Reach stackers 41–45 tons

MODEL		SMV 4127 - 4545 TBX5 to SMV 4123 - 4545 CBX5							
Engine		Units							
Make		Volvo	Scania	Scania	Cummins	Volvo	Scania	Volvo	Scania
Model		TAD-1340-VE	DC-13-074	DC-13-076	QSM-11-C335	TAD-1360-VE	DC-13-081	TAD-1361-VE	DC-13-077
Emission approval, EU / US		St 2 / Tier 2	St 2 / Tier 2	St 3a / Tier 3	St 3a / Tier 3	St 3b / Tier 4i	St 3b / Tier 4i	St 3b / Tier 4i	St 3b / Tier 4i
Power / max speed (ISO 3046)	kW/rpm	256 / 2100	257 / 2100	257 / 2100	272 / 2100	256 / 1900	257 / 2100	285 / 1900	294 / 2100
Torque @ speed (ISO 3046)	Nm/rpm	1770 / 1250	1950 / 1200	1640 / 1400	1674 / 1000	1740 / 1200	1950 / 1200	1940 / 1000	2172 / 1200
Displacement / cylinders	L/--	12.8 / 6-cyl	12.7 / 6-cyl	12.7 / 6-cyl	10.8 / 6-cyl	12.8 / 6-cyl	12.7 / 6-cyl	12.8 / 6-cyl	12.7 / 6-cyl
Alternator power / capacity	W/Amp	3080 / 110	2800 / 100	2800 / 100	1960 / 70	3080 / 110	2800 / 100	3080 / 110	2800 / 100
Fuel consumption (normal)	L/hour	12-16	12-16	12-16	12-16	12-16	12-16	14-20	14-20
Transmission (make / model)		DANA TE-27	DANA TE-27	DANA TE-27	DANA TE-27	DANA TE-27 (opt. ZF 4WG-261)	DANA TE-27 (opt. ZF 4WG-261)	DANA TE-32	DANA TE-32

MODEL		SMV 4127 - 4545 TBX5 to SMV 4123 - 4545 CBX5			
Transmission		Units			
Make		DANA	ZF	DANA	ZF
Model		TE-27400	4WG-261	TE-32400	4WG-311
Gear shift type		Automatic	Automatic	Automatic	Automatic
No. of gears (fwd / rev)	No.	4 / 4	4 / 3	4 / 4	4 / 3
Power rating (max)	kW	270	280	325	330

DIMENSION MEASUREMENT IDENTIFIERS

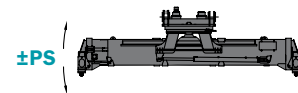
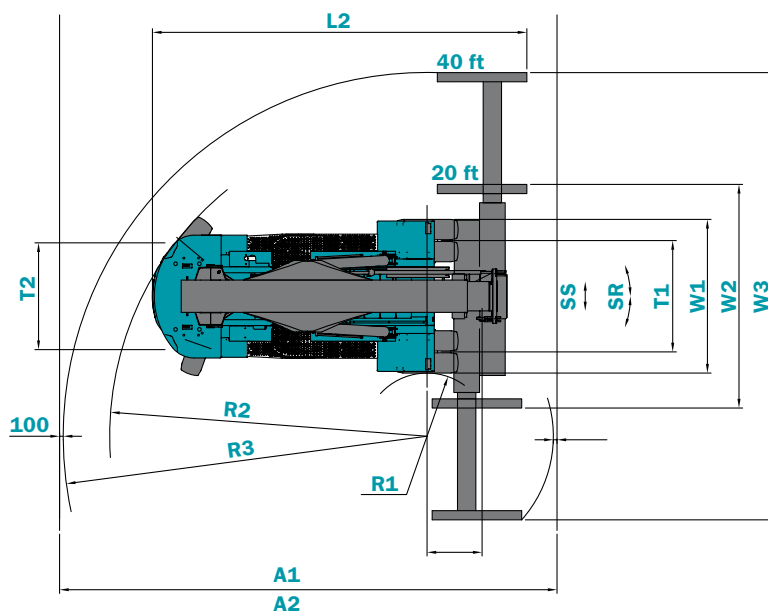
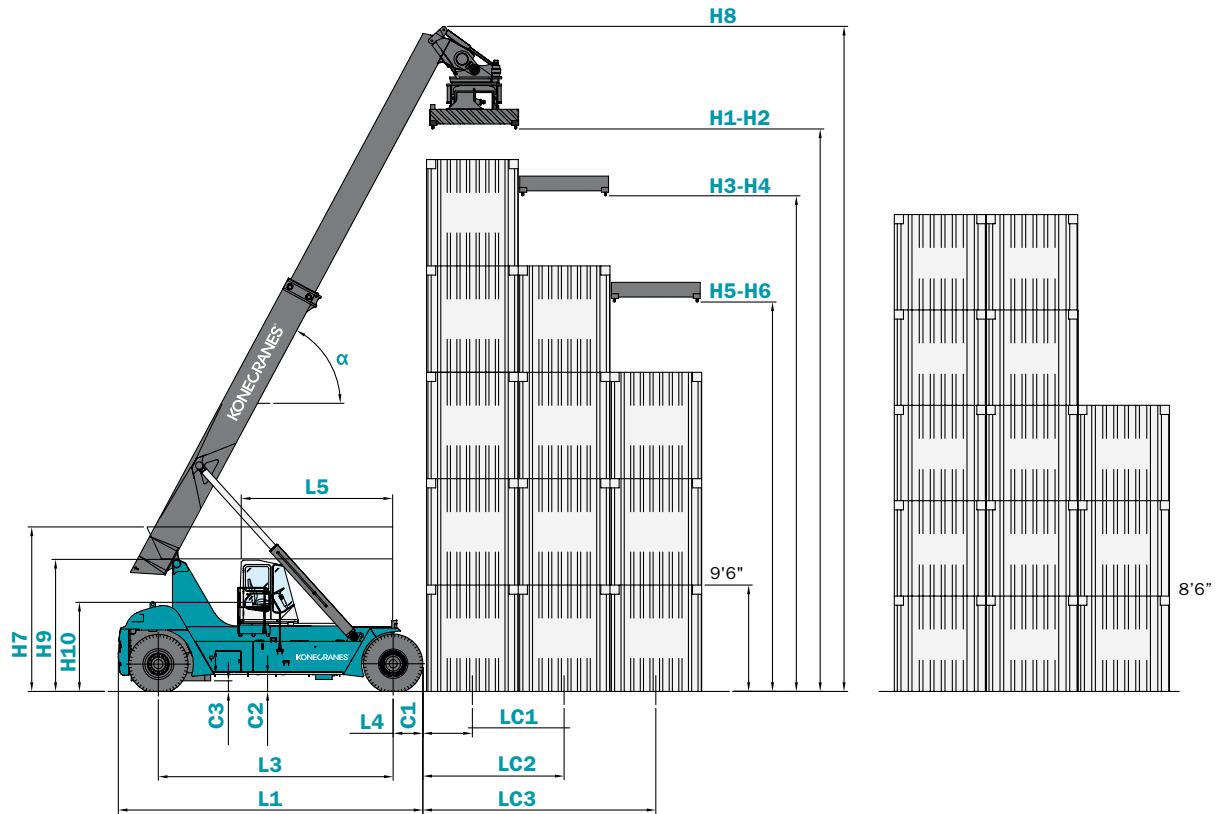

TECHNICAL DATA

Reach stackers for container handling, 41 to 45 tons

MODEL			SMV 4127 TB5	SMV 4527 TB5	SMV 4527 TB6	SMV 4531 TB5	
LIFTING DATA	Dimensions	Identifier	Units				
	Lifting capacity at load center LC1 / LC2 / LC3 (no jacks)		tons	41 / 27 / 14	45 / 27 / 14	45 / 27 / 14	45 / 31 / 16
	Lifting capacity at load center LC1 / LC2 / LC3 (with jacks)		tons	-	-	-	-
	Load centers in row 1 / 2 / 3	LC1 / LC2 / LC3	mm	2000 / 3850 / 6350	2000 / 3850 / 6350	2200 / 3850 / 6350	2000 / 3850 / 6350
	Stacking height in row 1 (9'6" / 8'6")			5 x 9'6" / 5 x 8'6"	5 x 9'6" / 5 x 8'6"	5 x 9'6" / 6 x 8'6"	5 x 9'6" / 5 x 8'6"
	Spreader type, telescopic, locking			Toplift with 4 x twistlocks, extension 20-40 ft, 4 lifting eyes, safety locking (ELME 817)			
WEIGHT	Lost load center to face of tires / jacks	L4	mm	800	800	800	800
	Wheelbase	L3	mm	6400	6400	6400	6400
WEIGHT	Service weight		kg	68500	68500	69200	71800
	Axle pressure front LC1 (unloaded / rated load)		kg	37500 / 96500	37500 / 102200	38200 / 104300	37500 / 102200
	Axle pressure rear LC1 (unloaded / rated load)		kg	42000 / 88600	42000 / 88600	42300 / 88900	42000 / 95500
	Axle pressure front LC2 (unloaded / rated load)		kg	31000 / 13000	31000 / 11300	31000 / 9900	34300 / 14600
	Axle pressure rear LC2 (unloaded / rated load)		kg	26500 / 6900	26500 / 6900	26900 / 7300	29800 / 7300
WHEELS	Tire type			Pneumatic	Pneumatic	Pneumatic	Pneumatic
	Tire dimension / ply rating, front & rear		Inch	18.00 x 25"/PR40	18.00 x 25"/PR40	18.00 x 25"/PR40	18.00 x 25"/PR40
	Rim dimensions, front & rear		Inch	13.00 x 25"	13.00 x 25"	13.00 x 25"	13.00 x 25"
	Tire pressure, front / rear		MPa	1.0 / 1.0	1.0 / 1.0	1.0 / 1.0	1.0 / 1.0
	Number of wheels, front / rear (X = driven)			4X / 2	4X / 2	4X / 2	4X / 2
	Track width, front / rear	T1 / T2	mm	3030 / 2911	3030 / 2911	3030 / 2911	3030 / 2911
DIMENSIONS	Boom angle, min - max	α	deg	0 - 62	0 - 62	0 - 62	0 - 62
	Lifting height in twistlocks, min - max at LC1	H1 - H2	mm	1150 - 15300	1150 - 15300	1150 - 15300	1150 - 15300
	Lifting height in twistlocks, min - max at LC2	H3 - H4	mm	1150 - 13400	1150 - 13400	1150 - 13400	1150 - 13400
	Lifting height in twistlocks, min - max at LC3	H5 - H6	mm	1150 - 10500	1150 - 10500	1150 - 10500	1150 - 10500
	Boom height, min - max	H7 - H8	mm	4500 - 18200	4500 - 18200	4500 - 18200	4500 - 18200
	Truck height over cabin / seat height	H9 - H10	mm	3650 - 2450	3650 - 2450	3650 - 2450	3650 - 2450
	Sliding cabin stroke (manual / hydraulic)	L5	mm	1800 / 2900	1800 / 2900	1800 / 2900	1800 / 2900
	Overall length, with - without spreader	L1 - L2	mm	11500 - 8300	11500 - 8300	11700 - 8300	11500 - 8300
	Drive axle width	W1	mm	4160	4160	4160	4160
	Spreader width, min - max	W2 - W3	mm	6050 - 12175	6050 - 12175	6050 - 12175	6050 - 12175
	Spreader sideshift	SS	mm	± 800	± 800	± 800	± 800
	Spreader rotation	SR	deg	-105 / 195	-105 / 195	-105 / 195	-105 / 195
	Mechanical Pile Slope (side tilt / no power)	PS	deg	± 2	± 2	± 2	± 2
	Ground clearance, front / mid / steering axle	C1 / C2 / C3	mm	300 / 465 / 275	300 / 465 / 275	300 / 465 / 275	300 / 465 / 275
Aisle width (with 20 ft / 40 ft container)	A1 / A2	mm	11500 / 13600	11500 / 13600	11800 / 13900	11500 / 13600	
Turning radius, inner	R1	mm	1500	1500	1500	1500	
Turning radius, outer 20 ft / outer 40 ft	R2 / R3	mm	8550 / 9850	8550 / 9850	8550 / 9900	8550 / 9850	
PERFORMANCE	Drive speed forward, unloaded / at rated load		km/h	25 / 22	25 / 22	25 / 22	24,5 / 22
	Drive speed reverse, unloaded / at rated load		km/h	25 / 22	25 / 22	25 / 22	24,5 / 22
	Lifting speed, unloaded / at 40% load / at rated load		m/s	0.38 / 0.35 / 0.23	0.38 / 0.35 / 0.23	0.38 / 0.35 / 0.23	0.38 / 0.35 / 0.23
	Lowering speed, unloaded / at rated load		m/s	0.35 / 0.40	0.35 / 0.40	0.35 / 0.40	0.35 / 0.40
	Gradeability, at rated load, 0/2 km/h		% / %	29 / 22	29 / 22	25 / 20	25 / 20
	Towing power, at rated load, 0/2 km/h		kN / kN	315 / 251	315 / 251	300 / 246	300 / 246
DRIVELINE	Engine power (min - max)	EU2 / EU3b	kW	256 - 294	256 - 294	256 - 294	256 - 294
	Engine torque (min - max)	EU2 / EU3b	Nm	1640 - 2172	1640 - 2172	1640 - 2172	1640 - 2172
	Transmission, gears forward + reverse			DANA 4 + 4 / ZF 4 + 3			
	Transmission type, function, shifting			Automatic transmission, torque converter, reverse protection, powershift			
	Drive axle model			Kessler D102			
	Driving brake system, type			Oil-cooled multiple wet disc brakes (WDB)			
	Parking brake system, type			Dry single disc / spring release			
Steering system / steering axle type			Hydraulic power steer / HD axle + double-acting cylinder				
OTHERS	Load-sensing hydraulics / power-on-demand		Yes / yes	Yes / yes	Yes / yes	Yes / yes	
	Safety, Monitoring & Overload System		Yes	Yes	Yes	Yes	
	Hydraulic oil pressure, boom / spreader		MPa	24 / 15	24 / 15	24 / 15	24 / 15
	Diesel / hydraulic tank volumes		Lit	650 / 850	650 / 850	650 / 850	650 / 850
	Noise level inside cab (LM) DIN 45635	EU2 / EU3b	dB(A)	68 / 66	68 / 66	68 / 66	68 / 66
	Noise level inside cab (LpAZ) EN 12053		dB(A)	75	75	75	75
Noise level outside (LWA) 2000/14/EC		dB(A)	111	111	111	111	

NOTE 1. TB models do not have support jacks / TBX models have support jacks for increased capacity and lower ground pressure

NOTE 2. Other lifting attachment combinations possible, check factory information

NOTE 3. Four lifting eyes on spreader are standard; extra ones can be provided plus container guides on one side of spreader

NOTE 4. Optional for laden handlers: Hydraulic Pile Slope ±6 deg and Powered Dampening Cylinders ±5 deg + tilt lock

NOTE 5. For available driveline combinations, see driveline chart and latest factory information

NOTE 6. BH = reach stacker for barge handling (other models available)

SMV 4531 TB6	SMV 4535 TB5 (TBX5)	SMV 4537 TB5 (TBX5)	SMV 4542 TB5 (TBX5)	SMV 4543 TB5 (TBX5)	SMV 4545 TB5 (TBX5)	SMV 4545 TB3 (BH)
45 / 31 / 16	45 / 35 / 20	45 / 37 / 19	45 / 42 / 24	45 / 42 / 25	45 / 45 / 37	45 / 45 / 35
-	45 / 37 / 24	45 / 41 / 28	45 / 44 / 30	45 / 44 / 34	45 / 45 / 45	45 / 45 / 35
2200 / 3850 / 6350	1900 / 3850 / 6350	2000 / 3850 / 6350	1800 / 3850 / 6350	1800 / 3850 / 6350	2275 / 3850 / 6350	1975 / 3875 / 6375
5 x 9'6" / 6 x 8'6"	5 x 9'6" / 5 x 8'6"	5 x 9'6" / 5 x 8'6"	5 x 9'6" / 5 x 8'6"	5 x 9'6" / 5 x 8'6"	5 x 9'6" / 5 x 8'6"	3 x 9'6" / 3 x 8'6"
800	930	930	930	930	1025	1025
6400	6400	6400	7250	7500	8000	9000
72500	79700	83000	83500	84500	107000	105200
38200 / 104300	38700 / 103400	42000 / 106700	42000 / 104400	42500 / 103700	51000 / 114600	52000 / 118300
42300 / 95800	43400 / 104400	46500 / 110100	46400 / 116000	47100 / 116000	54600 / 127200	57300 / 121200
34300 / 13200	41000 / 21300	41000 / 21300	41500 / 24100	42000 / 25800	56000 / 37400	53200 / 31900
30200 / 7700	36300 / 10300	36500 / 9900	37100 / 9500	37400 / 10500	52400 / 24800	47900 / 20100
Pneumatic	Pneumatic	Pneumatic	Pneumatic	Pneumatic	Pneumatic	Pneumatic
18.00 x 25"/PR40	18.00 x 33"/PR36	18.00 x 33"/PR36	18.00 x 33"/PR36	18.00 x 33"/PR36	21.00x35"/PR40	21.00 x 35"/PR40
13.00 x 25"	13.00 x 33"	13.00 x 33"	13.00 x 33"	13.00 x 33"	15.00 x 35"	15.00 x 35"
1.0 / 1.0	1.0 / 1.0	1.0 / 1.0	1.0 / 1.0	1.0 / 1.0	1.0 / 1.0	1.0 / 1.0
4X / 2	4X / 2	4X / 2	4X / 2	4X / 2	4X / 2	4X / 2
3030 / 2911	3030 / 2911	3030 / 2911	3030 / 2911	3030 / 2911	3227 / 3420	3227 / 3420
0 - 62	0 - 62	0 - 62	0 - 61	0 - 59	0 - 55	0 - 62
1150 - 16300	1300 - 15400	1300 - 15400	1300 - 15400	1300 - 15400	1300 - 15400	1300 - 15400
1150 - 14200	1300 - 13500	1300 - 13500	1300 - 13500	1300 - 13500	1300 - 14600	1300 - 13500
1150 - 11500	1300 - 10500	1300 - 10600	1300 - 10400	1300 - 10400	1300 - 11600	1300 - 10500
4500 - 19300	4675 - 18350	4775 - 18400	4775 - 18500	4975 - 18500	5100 - 18800	4675 - 18300
3650 - 2450	3800 - 2650	3800 - 2650	3800 - 2650	3800 - 2650	4050 - 2900	3800 - 2650
1800 / 2900	1800 / 2900	1800 / 2900	1800 / 2900	1800 / 2900	1800 / 2900	1800 / 2900
11700 - 8300	11500 - 8450	11500 - 8450	12300 - 9300	12550 - 9550	14150 - 10600	11500 - 8450
4160	4160	4160	4160	4160	4600	4160
6050 - 12175	6050 - 12175	6050 - 12175	6050 - 12175	6050 - 12175	6050 - 12175	6050 - 12175
± 200	± 800	± 800	± 800	± 800	± 800	± 800
± 200	-105 / 195	-105 / 195	-105 / 195	-105 / 195	-105 / 195	-105 / 195
± 5	± 2	± 2	± 2	± 2	± 2	± 2
300 / 465 / 275	300 / 425 / 450	300 / 425 / 450	300 / 425 / 450	300 / 425 / 450	300 / 300 / 500	300 / 300 / 500
11800 / 13900	11500 / 13600	11500 / 13600	12650 / 13850	12900 / 14000	15200 / 15400	15900 / 15900
1500	1500	1500	2200	2600	2800	3250
8550 / 9900	8550 / 9850	8550 / 9850	9750 / 10400	10100 / 10750	11300 / 11300	12400 / 12400
24,5 / 22	26 / 23	25 / 22,5	25 / 22,5	25 / 22,5	24 / 20	24 / 20
24,5 / 22	26 / 23	25 / 22,5	25 / 22,5	25 / 22,5	24 / 20	24 / 20
0.38 / 0.35 / 0.23	0.38 / 0.35 / 0.23	0.38 / 0.35 / 0.23	0.38 / 0.35 / 0.23	0.37 / 0.34 / 0.22	0.35 / 0.33 / 0.17	0.35 / 0.33 / 0.17
0.35 / 0.40	0.35 / 0.40	0.35 / 0.40	0.35 / 0.40	0.35 / 0.40	0.25 / 0.35	0.25 / 0.35
25 / 20	24 / 18	24 / 18	23 / 17	23 / 17	22 / 16	22 / 16
300 / 246	260 / 214	260 / 214	260 / 214	260 / 214	260 / 214	260 / 214
256 - 294	256 - 294	256 - 294	256 - 294	256 - 294	256 - 294	256 - 294
1640 - 2172	1640 - 2172	1640 - 2172	1640 - 2172	1640 - 2172	1640 - 2172	1640 - 2172
			Kessler D106		Kessler D111	Kessler D111
Yes / yes	Yes / yes	Yes / yes	Yes / yes	Yes / yes	Yes / yes	Yes / yes
Yes	Yes	Yes	Yes	Yes	Yes	Yes
24 / 15	24 / 15	24 / 15	25 / 15	25 / 15	24 / 15	24 / 15
650 / 850	650 / 850	650 / 850	650 / 850	650 / 850	700 / 950	700 / 950
68 / 66	68 / 66	68 / 66	68 / 66	68 / 66	68 / 66	68 / 66
75	75	75	75	75	75	75
111	111	111	111	111	111	111

This publication is for general informational purposes only and we reserve the right at any time to alter the product design and specifications. No statement of this publication shall be construed as a warranty or condition, express or implied, as to any product, its fitness for any particular purpose, merchantability, quality or representation of the terms of any sales agreement.

TECHNICAL DATA

Reach stackers for container handling, 10 to 25 tons

MODEL			SMV 108 TB6	SMV 2115 TB3	SMV 2518 TB3	
LIFTING DATA	Dimensions	Identifier	Units			
	Lifting capacity at load center LC1 / LC2 / LC3 (no jacks)		tons	10 / 8 / 5	21 / 15 / 5	25 / 18 / 8
	Lifting capacity at load center LC1 / LC2 / LC3 (with jacks)		tons	-	-	-
	Load centers in row 1 / 2 / 3	LC1 / LC2 / LC3	mm	2700 / 3850 / 6350	1750 / 3850 / 6350	1750 / 3850 / 6350
	Stacking height in row 1 (9'6" / 8'6")			5 x 9'6" / 6 x 8'6"	3 x 9'6" / 3 x 8'6"	3 x 9'6" / 3 x 8'6"
	Spreader type, telescopic, locking			ELME 517 (20-40 ft)	ELME 817 (20-40 ft)	ELME 327 (20 ft)
	Lost load center to face of tires / jacks	L4	mm	700	750	750
Wheelbase	L3	mm	5000	5500	5500	
WEIGHT	Service weight		kg	39500	56600	50000
	Axle pressure front LC1 (unloaded / rated load)		kg	21800 / 38600	29500 / 60100	24500 / 60900
	Axle pressure rear LC1 (unloaded / rated load)		kg	23600 / 38900	34600 / 62200	27800 / 60900
	Axle pressure front LC2 (unloaded / rated load)		kg	17700 / 10900	25100 / 15500	25500 / 14100
	Axle pressure rear LC2 (unloaded / rated load)		kg	15900 / 8600	20000 / 7400	22200 / 7100
WHEELS	Tire type			Pneumatic	Pneumatic	Pneumatic
	Tire dimension / ply rating, front & rear		Inch	14.00 x 24"/PR24	16.00 x 25"/PR32	16.00 x 25"/PR32
	Rim dimensions, front & rear		Inch	10.00 x 24"	11.25 x 25"	11.25 x 25"
	Tire pressure, front / rear		MPa	0.9 / 0.9	0.9 / 0.9	0.9 / 0.9
	Number of wheels, front / rear (X = driven)			4X / 2	4X / 2	4X / 2
	Track width, front / rear	T1 / T2	mm	3286 / 2290	2438 / 2656	2438 / 2656
DIMENSIONS	Boom angle, min - max	α	deg	0 - 66	0 - 47	0 - 47
	Lifting height in twistlocks, min - max at LC1	H1 - H2	mm	1150 - 16200	1200 - 11110	1200 - 11110
	Lifting height in twistlocks, min - max at LC2	H3 - H4	mm	1150 - 13700	1200 - 9000	1200 - 9000
	Lifting height in twistlocks, min - max at LC3	H5 - H6	mm	1150 - 11000	1200 - 7600	1200 - 7600
	Boom height, min - max	H7 - H8	mm	3900 - 18600	4150 - 14300	4150 - 14300
	Truck height over cabin / seat height	H9 - H10	mm	3300 - 2200	3400 - 2250	3400 - 2250
	Sliding cabin stroke (manual / hydraulic)	L5	mm	1800 / 1800	1800 / 1800	1800 / 1800
	Overall length, with - without spreader	L1 - L2	mm	10600 - 6650	10300 - 7300	10300 - 7300
	Drive axle width	W1	mm	4100	3420	3420
	Spreader width, min - max	W2 - W3	mm	6050 - 12175	6050 - 12175	6050
	Spreader sideshift	SS	mm	± 800	± 800	± 800
	Spreader rotation	SR	deg	-105 / 195	-105 / 195	-105 / 195
	Mechanical Pile Slope (side tilt / no power)	PS	deg	± 2	± 2	± 2
	Ground clearance, front / mid / steering axle	C1 / C2 / C3	mm	300 / 450 / 220	300 / 375 / 200	300 / 375 / 200
Aisle width (with 20 ft / 40 ft container)	A1 / A2	mm	10500 / 14000	10400 / 13300	10400	
Turning radius, inner	R1	mm	100	1400	1400	
Turning radius, outer 20 ft / outer 40 ft	R2 / R3	mm	6500 / 8400	7550 / 9200	7550	
PERFORMANCE	Drive speed forward, unloaded / at rated load		km/h	30 / 30	24 / 22	24 / 22
	Drive speed reverse, unloaded / at rated load		km/h	30 / 30	24 / 22	24 / 22
	Lifting speed, unloaded / at 40% load / at rated load		m/s	0.55 / 0.53 / 0.40	0.40 / 0.38 / 0.24	0.40 / 0.38 / 0.24
	Lowering speed, unloaded / at rated load		m/s	0.45 / 0.45	0.45 / 0.45	0.45 / 0.45
	Gradeability, at rated load, 0/2 km/h		% / %	29 / 23	31 / 21	31 / 21
	Towing power, at rated load, 0/2 km/h		kN / kN	144 / 118	190 / 147	190 / 147
DRIVELINE	Engine power (min - max)	EU2 / EU3b	kW	180 - 201	180 - 201	180 - 201
	Engine torque (min - max)	EU2 / EU3b	Nm	990 - 1180	990 - 1180	990 - 1180
	Transmission, gears forward + reverse			DANA 3+3 / ZF 4+3		
	Transmission type, function, shifting			Automatic transmission, torque converter, reverse protection, powershift		
	Drive axle model			Kessler D81	Kessler D91	
	Driving brake system, type			Oil-cooled multiple wet disc brakes (WDB)		
	Parking brake system, type			Dry single disc / spring release		
Steering system / steering axle type			Hydraulic power steer / HD axle + double-acting cylinder			
OTHERS	Load-sensing hydraulics / power-on-demand		Yes / yes	Yes / yes	Yes / yes	
	Safety, Monitoring & Overload System		Yes	Yes	Yes	
	Hydraulic oil pressure, boom / spreader		MPa	23 / 14	24 / 15	24 / 15
	Diesel / hydraulic tank volumes		Lit	430 / 600	430 / 600	430 / 600
	Noise level inside cab (LM) DIN 45635	EU2 / EU3b	dB(A)	68 / 66	68 / 66	68 / 66
	Noise level inside cab (LpAZ) EN 12053		dB(A)	75	75	75
Noise level outside (LWA) 2000/14/EC		dB(A)	110	110	110	

NOTE 1. TB models do not have support jacks

NOTE 2. Other lifting attachment combinations possible, check factory information

NOTE 3. Four lifting eyes on spreader are standard; extra ones can be provided plus container guides on one side of spreader

NOTE 4. Optional for laden handlers: Hydraulic Pile Slope ±6 deg and Powered Dampening Cylinders ±5 deg + tilt lock

NOTE 5. For available driveline combinations, see driveline chart and latest factory information

Reach stackers for intermodal handling, 41 to 45 tons

SMV 4123 CB5	SMV 4527 CB5	SMV 4531 CB5 (CBX5)	SMV 4533 CB5 (CBX5)	SMV 4537 CB5 (CBX5)	SMV 4538 CB5 (CBX5)	SMV 4545 CB5 (CBX5)
41 / 23 / 9	45 / 27 / 13	45 / 31 / 16	45 / 33 / 16	45 / 37 / 22	45 / 38 / 23	45 / 45 / 33
-	-	45 / 33 / 20	45 / 37 / 24	45 / 40 / 28	45 / 40 / 32	45 / 45 / 45
2000 / 3850 / 6350	1900 / 3850 / 6350	1900 / 3850 / 6350	2000 / 3850 / 6350	1800 / 3850 / 6350	1800 / 3850 / 6350	2275 / 3850 / 6350
5 x 9'6" / 5 x 8'6"	5 x 9'6" / 5 x 8'6"	5 x 9'6" / 6 x 8'6"	5 x 9'6" / 5 x 8'6"	5 x 9'6" / 5 x 8'6"	5 x 9'6" / 5 x 8'6"	5 x 9'6" / 5 x 8'6"
Toplift 4 x twistlocks, trailer lift 4 x lifting legs, extension 20-30-35-40 ft, 4 lifting eyes, safety locking (ELME 857)						
800	930	930	930	930	930	1025
6400	6400	6400	6400	7250	7500	8000
72500	77600	82200	87200	89500	90000	110000
43000 / 101900	44200 / 108900	44200 / 108900	48000 / 112700	48000 / 110400	48000 / 109200	54000 / 117600
48700 / 88500	50200 / 97500	50200 / 104200	53600 / 110400	53500 / 114800	53700 / 116100	58400 / 131000
29500 / 11600	33400 / 13700	38000 / 18300	39200 / 19500	41500 / 24100	42000 / 25800	56000 / 37400
23800 / 7000	27400 / 7100	32000 / 9000	33600 / 8900	36000 / 11700	36300 / 11900	51600 / 24000
Pneumatic	Pneumatic	Pneumatic	Pneumatic	Pneumatic	Pneumatic	Pneumatic
18.00 x 25"/PR40	18.00 x 33"/PR36	18.00 x 33"/PR36	18.00 x 33"/PR36	18.00 x 33"/PR36	18.00 x 33"/PR36	21.00 x 35"/PR40
13.00 x 25"	13.00 x 33"	13.00 x 33"	13.00 x 33"	13.00 x 33"	13.00 x 33"	15.00 x 35"
1.0 / 1.0	1.0 / 1.0	1.0 / 1.0	1.0 / 1.0	1.0 / 1.0	1.0 / 1.0	1.0 / 1.0
4X / 2	4X / 2	4X / 2	4X / 2	4X / 2	4X / 2	4X / 2
3030 / 2911	3030 / 2911	3030 / 2911	3030 / 2911	3030 / 2911	3030 / 2911	3227 / 3420
0 - 62	0 - 62	0 - 62	0 - 62	0 - 61	0 - 59	0 - 55
650 - 14800	800 - 14900	800 - 14900	800 - 14900	800 - 14900	800 - 14900	1300 - 15000
650 - 13000	800 - 13000	800 - 13000	800 - 13000	800 - 13000	800 - 13000	1300 - 14100
650 - 10100	800 - 10000	800 - 10000	800 - 10000	800 - 9900	800 - 9900	1300 - 11100
4500 - 18200	4675 - 18350	4675 - 18350	4775 - 18400	4775 - 18500	4975 - 18500	5100 - 18800
3650 - 2450	3800 - 2650	3800 - 2650	3800 - 2650	3800 - 2650	3800 - 2650	4050 - 2900
2900	2900	2900	2900	2900	2900	2900
11500 - 8300	11550 - 8450	11550 - 8450	11550 - 8450	12300 - 9300	12550 - 9550	14150 - 10600
4160	4160	4160	4160	4160	4160	4600
6050 - 12175	6050 - 12175	6050 - 12175	6050 - 12175	6050 - 12175	6050 - 12175	6050 - 12175
± 800	± 800	± 800	± 800	± 800	± 800	± 800
-105 / 195	-105 / 195	-105 / 195	-105 / 195	-105 / 195	-105 / 195	-105 / 195
± 6	± 6	± 6	± 6	± 6	± 6	± 6
300 / 465 / 275	300 / 465 / 450	300 / 465 / 450	300 / 425 / 450	300 / 425 / 450	300 / 425 / 450	300 / 300 / 500
11500 / 13600	11500 / 13600	11500 / 13600	11500 / 13600	12650 / 13850	12900 / 14000	15200 / 15400
1500	1500	1500	1500	2200	2200	2800
8550 / 9850	8550 / 9850	8550 / 9850	8550 / 9850	9750 / 10400	10100 / 10750	11300 / 11300
24.5 / 22	26 / 23	26 / 23	25 / 22.5	24.5 / 22	24.5 / 22	25 / 20
24.5 / 22	26 / 23	26 / 23	25 / 22.5	24.5 / 22	24.5 / 22	25 / 20
0.38 / 0.35 / 0.23	0.38 / 0.35 / 0.23	0.38 / 0.35 / 0.23	0.38 / 0.35 / 0.23	0.38 / 0.35 / 0.23	0.38 / 0.35 / 0.23	0.35 / 0.33 / 0.17
0.35 / 0.40	0.35 / 0.40	0.35 / 0.40	0.35 / 0.40	0.35 / 0.40	0.35 / 0.40	0.25 / 0.35
25 / 20	24 / 18	24 / 18	24 / 18	23 / 17	23 / 17	22 / 16
300 / 246	260 / 214	260 / 214	260 / 214	260 / 214	260 / 214	260 / 214
256 - 294	256 - 294	256 - 294	256 - 294	256 - 294	256 - 294	256 - 294
1640 - 2172	1640 - 2172	1640 - 2172	1640 - 2172	1640 - 2172	1640 - 2172	1640 - 2172
DANA 4 + 4 / ZF 4 + 3						
Fully automatic transmission, torque converter, reverse protection, powershift						
Kessler D102				Kessler D106		Kessler D111
Oil-cooled multiple wet disc brakes (WDB)						
Dry single disc / spring release						
Hydraulic power steer / HD axle + double-acting cylinder						
Yes / yes	Yes / yes	Yes / yes	Yes / yes	Yes / yes	Yes / yes	Yes / yes
Yes	Yes	Yes	Yes	Yes	Yes	Yes
24 / 15	24 / 15	24 / 15	24 / 15	25 / 15	25 / 15	24 / 15
650 / 850	650 / 850	650 / 850	650 / 850	650 / 850	650 / 850	700 / 950
68 / 66	68 / 66	68 / 66	68 / 66	68 / 66	68 / 66	68 / 66
75	75	75	75	75	75	75
111	111	111	111	111	111	111

NOTE 1. CB models do not have support jacks / CBX models have support jacks for increased capacity and lower ground pressure

NOTE 2. Other lifting attachment combinations possible, check factory information

NOTE 3. Four lifting eyes on spreader are standard; extra ones can be provided plus container guides on one side of spreader

NOTE 4. Standard for intermodal handlers: Hydraulic Pile Slope ±6 deg and Powered Dampening Cylinders ±5 deg + tilt lock

NOTE 5. For available driveline combinations, see driveline chart and latest factory information



INDUSTRIAL
CRANES



NUCLEAR
CRANES



PORT
CRANES



HEAVY-DUTY
LIFT TRUCKS



SERVICE



MACHINE
TOOL
SERVICE



Konecranes is a world-leading group of Lifting Businesses™ offering lifting equipment and services that improve productivity in a wide variety of industries. The company is listed on NASDAQ OMX Helsinki Ltd (symbol: KCR1V). With over 11,500 employees at more than 600 locations in almost 50 countries we have the resources, technology and determination to deliver on the promise of Lifting Businesses™.

© 2012 Konecranes. All rights reserved. "Konecranes", "Lifting Businesses" and  are registered trademarks of Konecranes.



Konecranes Liftrucks AB Box 103, SE-285 23 Markaryd, Sweden
Tel. +46 433 73300, Fax +46 433 73310, E-mail: info.liftrucks@konecranes.com
www.konecranesliftrucks.se www.konecranes.com